

EM-9B WIRING DIAGRAM

(For "EM-9B", 1½ HP, 3000 RPM, Single Phase, 50 HZ, 220 Volt, Explosion-proof Motor, Manufactured by Franklin Electric/Bluffton Motor Works.)

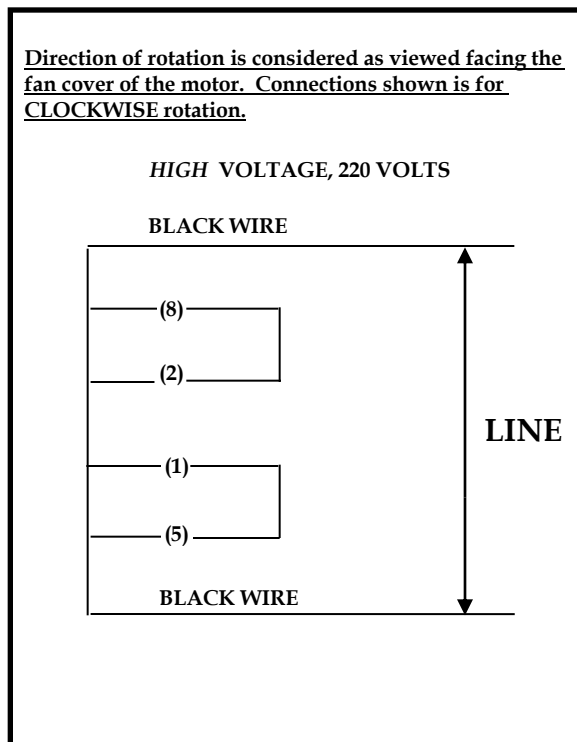

IMPORTANT:

Pump/motor combinations shipped from the factory are always set for correct rotation.

These motors are provided with an automatic-reset thermal overload device.

Connection shown is for CLOCKWISE rotation.

To change motor rotation, interchange wires (5) and (8).



MAKE SURE THE ELECTRIC MOTOR IS APPROPRIATELY GROUNDED. USE THE GROUND LEAD PROVIDED. IF THE GROUND LEAD IS NOT PROVIDED CONTACT THE FACTORY .



SMITH PRECISION PRODUCTS COMPANY

P.O. Box 276, Newbury Park, CA 91319 USA
1299 Lawrence Drive, Newbury Park, CA 91320 USA

Tel.: 805/498-6616 FAX: 805/499-2867

e-mail: INFO@smithpumps.com web: www.smithpumps.com